

GLOBAL JOURNAL OF ENGINEERING SCIENCE AND RESEARCHES POTENTIAL CAPABILITY OF LTE-ADVANCED PHYSICAL LAYER

MD.Asif

Assistant Professor , Department of Electronics and Communication Engineering, K G Reddy College of Engineering and Techology, India

ABSTRACT

LTE-Advanced (LTE-A) is usually referred as 4G Communication is the evolved version of LTE that is being developed by 3GPP. LTE-A will meet or exceed the requirements of the International Telecommunication Union (ITU) for the Fourth Generation (4G) radio communication standard known as IMT-Advanced. LTE-A is being specified initially as part of Release 10 of the 3GPP specifications. In this paper, we present an in-depth analysis of the LTE-A downlink physical layer characteristics and its performance. The work analyzes a detailed potential ability study of Physical layer in LTE-Advanced based on Release 10 of the 3GPP standard. As performance metrics, Bit Error Rate (BER) and data throughput are evaluated in terms of Signal to Noise Ratio (SNR) for two different Multi-Input Multi-Output (MIMO) schemes as defined in LTE standard under different combination of digital modulation schemes.

This study consider a first step to perform hardware implementation of LTE-A system using Field Programmable Gate Array (FPGA) technology that plays a vital role for mobile communication and wireless communication network.

Keywords: *Long Term Evolution (LTE), Long Term Evolution Advanced (LTE-A), Multi-Input Multi-Output (MIMO), Evolved Node B (eNB), User Equipment (UE), Signal to Noise Ratio(SNR), Data Throughput..*

I. INTRODUCTION

Wireless communications have evolved from the so-called second generation (2G) systems of the early 1990s, which first introduced digital cellular technology, through the deployment of third generation (3G) systems with their higher speed data networks to the much-anticipated fourth generation technology being developed today. This evolution is illustrated in Fig.1, which shows that fewer standards are being proposed for 4G than in previous generations, with only two 4G candidates being actively developed today: 3GPP LTE-Advanced and IEEE 802.16m, which is the evolution of the WiMAX standard known as Mobile WiMAX [1].

The Long Term Evolution project was initiated in 2004. The motivation for LTE included the desire for a reduction in the cost per bit, the addition of lower cost services with better user experience, the flexible use of new and existing frequency bands, a simplified and lower cost network with open interfaces, and a reduction in terminal complexity with an allowance for reasonable power consumption.

These high level goals led to further expectations for LTE, including reduced latency for packets, and spectral efficiency improvements above Release 6 high speed packet access (HSPA) of three to four times in the downlink and two to three times in the uplink. Flexible channel bandwidths - a key feature of LTE - are specified at 1.4, 3, 5, 10, 15, and 20 MHz in both the uplink and the downlink. This allows LTE to be flexibly deployed where other systems exist today, including narrowband systems such as GSM and some systems in the U.S. based on 1.25MHz. Unlike previous systems, LTE is designed from the beginning to use MIMO technology, which results in a more integrated approach to this advanced antenna technology than does the addition of MIMO to legacy system such as HSPA

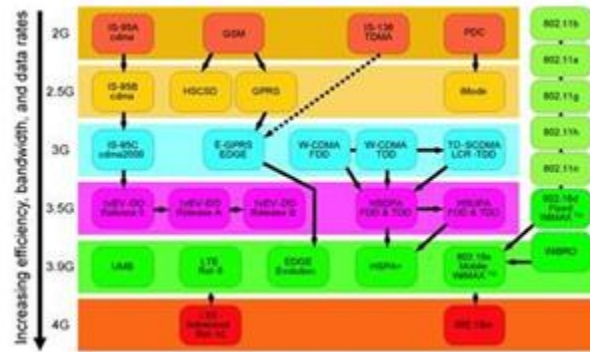

Fig.1 Wireless evolution 1990-2011 and beyond

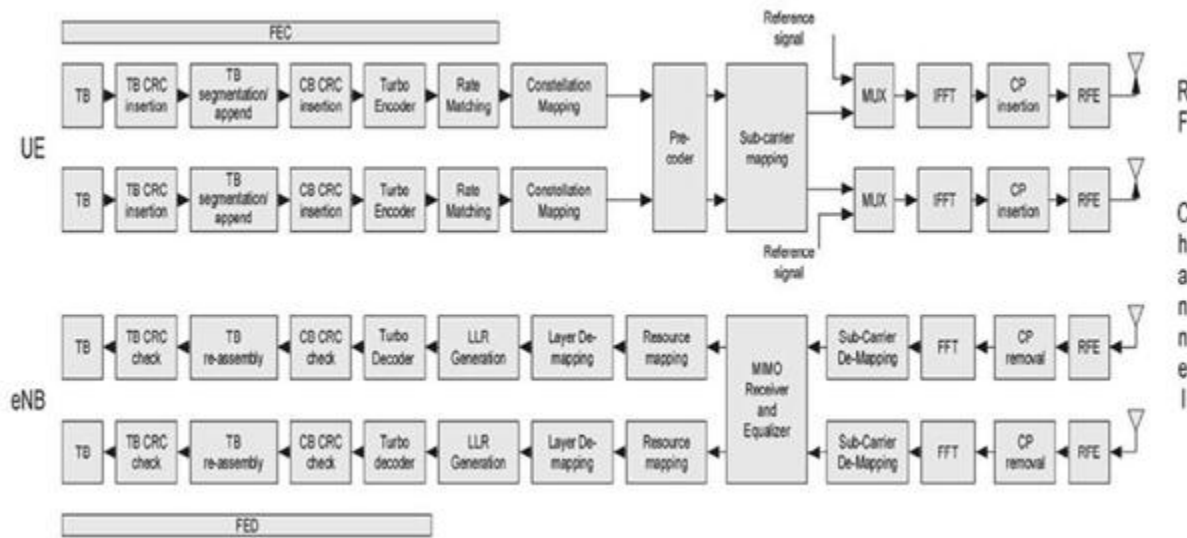

Fig. 2 Downlink PHY block diagram [8].

Finally, in terms of mobility, LTE is aimed primarily at low mobility applications in the 0 to 15 km/h range, where the highest performance will be seen. The system is capable of working at higher speeds and will be supported with high performance from 15 to 120 km/h and functional support from 120 to 350 km/h. Support for speeds of 350 to 500 km/h is under consideration.

In the feasibility study for LTE-A, 3GPP determined that LTE-A would meet the ITU-R requirements for 4G. The results of the study are published in 3GPP Technical Report (TR) 36.912. Further, it was determined that 3GPP Release 8 LTE could meet most of the 4G requirements apart from uplink spectral efficiency and the peak data rates.

These requirements are addressed with the addition of the following LTE-A features:

- Wider bandwidths, enabled by carrier aggregation.
- Higher efficiency enabled by enhanced uplink multiple access and enhanced multiple antenna transmission (advanced MIMO techniques).
- Coordinated multipoint transmission and reception (CoMP).
- Relaying.
- Support for heterogeneous networks.
- LTE self-optimizing network (SON) enhancements.
- Home enhanced node B (HeNB).

- Fixed wireless customer premises equipment (CPE) RF requirements.

II. LTE DOWNLINK PHY LAYER DESCRIPTION

The role of the PHY layer is to encode the binary digits that represent MAC frames into signals and to transmit and receive these signals across the communication media. This simulation shows the Downlink Shared Channel (eNodeB to UE) processing of the LTE PHY specifications developed by the Third Generation Partnership Project (3GPP) [2 - 7]. Fig.2 shows a block diagram for a downlink (eNB to UE) connection.

The model shows the Release 10 modes of 2-by-2 and 4- by-4 antenna configurations using UE category 5 parameters and the frequency division duplex (FDD) mode of the specifications and thus uses a radio frame of 10 ms composed of 10 subframes. Each subframe of 1 ms duration has two consecutive slots.

The downlink shared channel processing at the base station (eNodeB) includes transport channel processing and physical channel processing, with corresponding duality at the receiver (UE) to retrieve the transmitted data bits. The following sub-sections briefly describe the processing involved, with reference to the relevant sections of the LTE standard [2].

Resources

The transport channel is the interface between the physical layer and the MAC layer. As the LTE simulation focuses on the physical layer, the initial data is generated in the form of transport blocks

In the spatial multiplexing transmission mode, two transport blocks at the same time are prepared for transmission. The size of various fields in the time domain is expressed as a number of time units $T_s = 1 / (1500 \times 2048)$ seconds. Downlink and uplink transmissions are organized into radio frames with $T_f = 307200 \times T_s = 10$ ms duration. Frame structure type 1 is supported as shown in Fig. 3 [2]



Fig. 3 Frame structure type I [2].

CRC for Transport Block

A Cyclic Redundancy Check (CRC) is added to the Transport Block (TB) to allow integrity checking. A CRC schemes for Physical Downlink Shared Channel (PDSCH) is gCRC24A according to LTE standard [3].

Code Block Segmentation and Code Block CRC

Due to the turbo-coding interleaver block lengths supported by LTE (a maximum of 6144 bits), any transport block that exceeds this size is segmented into smaller code- blocks. Another CRC is added to each code block and CRC for Code Block is gCRC24B [3].

Turbo Coding

The turbo encoder is used to encode the data rate 1/3 coding rate.

The scheme of turbo encoder is a Parallel Concatenated Convolutional Code (PCCC) with two 8-state constituent encoders and one turbo code internal interleaver. The structure of turbo encoder is illustrated in Fig. 4 [4].

The transfer function of the 8-state constituent code for the PCCC is:

$$\{x(L)\} = \left\lfloor \frac{\{g_0(D)\}}{\{g_1(D)\}} \right\rfloor \quad (1)$$

Where

$$g_0(D) = 1 + D^2 + D^3$$

$$g_1(D) = 1 + D + D^2$$

The output from the turbo encoder consists of three information bit streams with the same length k :

- Systematic bit stream: $(x_k, k = 0, 1, \dots, k - 1)$
- Parity bit stream: $(z_k, k = 0, 1, \dots, k - 1)$
- Interleaved parity bit stream: $(z_{\square k}, k = 0, 1, \dots, k - 1)$
-

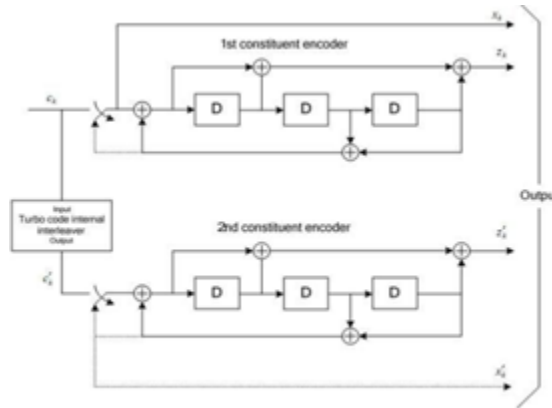

Fig. 4 Structure of rate 1/3 turbo encoder (dotted lines apply for trellis termination only).

Rate Matching

The main task of the Rate matching is to extract the exact set of bits to be transmitted within a given subframe from the encoded bits. The sub-block interleaving is implemented by creation of the circular buffer and the actual bit selection using UE categories parameters of LTE standard [2].

PDSCH Processing

A physical channel corresponds to a set of time-frequency resources used for transmission of a particular transport channel. Each transport channel maps to a corresponding physical channel as shown in the Fig.5 [2]. The PDSCH is the main physical channel used for unicast data transmission. We use spatial multiplexed codebook-based transmission, and, as a result, the downlink physical channel processing includes:

Scrambling

The transport channel encoded bits are scrambled by a bit- level scrambling sequence. The scrambling sequence depends on the physical layer cell identity to ensure interference randomization between cells.

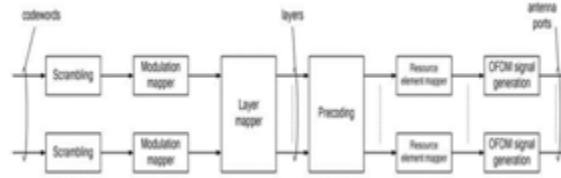

Fig. 5 Overview of physical channel processing

Adaptive Modulation

Adaptive modulation technique allows to maintain the BER below a predefined target value by modifying the signal transmitted to a particular user according to the instantaneous received signal quality. Additionally, the coding scheme may be also modified along the time to match the instantaneous channel conditions for each user, then being denoted as Adaptive Modulation and Coding (AMC). In this case, both modulation and coding scheme are jointly changed by the transmitter to adapt the transmitted signal to the varying channel conditions (in time and frequency domains).

LTE supports a variety of modulation and coding schemes and allows for the scheme to change on a burst-by-burst basis per link, depending on channel and interference conditions. The set of modulation schemes supported include QPSK, 16QAM and 64QAM,

Antenna Mapping

Antenna mapping is the combination of layer mapping and pre-coding, which jointly process the modulation symbols for one or two codewords to make them transmit on different antenna ports. The structure of antenna mapping is illustrated in Fig.6.

Layer Mapping

The complex modulated symbols from both codewords are mapped to layers (antenna ports) as LTE standard [2]. Since full rank transmission is assumed, the number of layers is equal to the number of transmit antennas.

In the layer mapping, the modulation symbols for one or two codewords will be mapped onto one or several layers. In case of spatial multiplexing, there may be one or two code-words. But the number of layers is restricted. On one hand, it should be equal to or more than the number of codewords.

On the other hand, the number of layers cannot exceed the number of antenna ports. The most important thing is the concept of ‘layer’. The layers in spatial multiplexing have

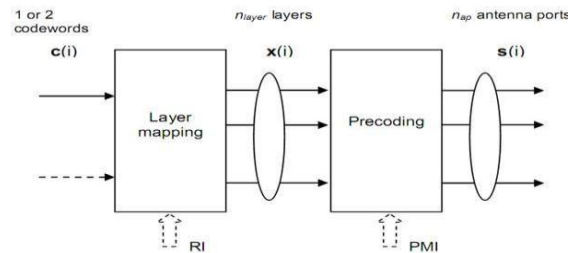

Fig. 6 the structure of antenna mapping

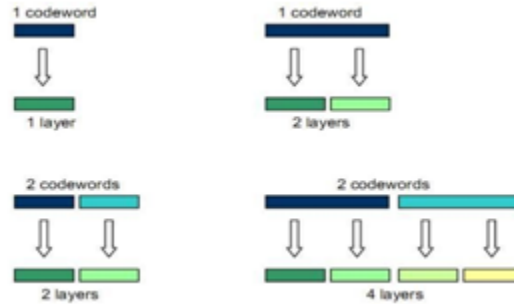

Fig. 7 layer mapping for spatial multiplexing.

the same meaning as ‘streams’. They are used to transmit multiple data streams in parallel, so the number of layers here is often referred to as the transmission rank [9]. In spatial multiplexing, the number of layers may be adapted to the transmission rank, by means of the feedback of a Rank Indicator (RI) to the layer mapping, as Fig.6 shows. The implementation of layer mapping for spatial multiplexing is depicted in Fig.7 [10].

Codebook-based Precoding

The modulated symbols per layer are precoded using the codebooks specified in LTE standard [2]. Pre-coder is applied according to the antenna configuration chosen for the path. The signal is then mapped directly onto the sub-carriers in one or more Resource Blocks (RBs). Each RB is a set of 12 sub-carriers by one symbol. According to the specification [2], there are two codebooks of the pre-coder matrices. One codebook is for two antenna ports and one and two layers. The other codebook is for four antenna ports and one, two, three and four layers. Both closed-loop spatial multiplexing and open-loop spatial multiplexing use these codebooks. Note that for all the transmission modes, the total power of the signals does not change after the implementation of pre- coding [11].

Resource Element Mapping

The precoded symbols to be transmitted on each antenna are mapped to the resource elements of the resource blocks available for transmission. The number of available resource blocks is a function of the Channel bandwidth parameter on the Model Parameters block, as per the Table.1 (reproduced from LTE standard [7]).

Table 1: Resources block of different channel bandwidth

$BW_{channel}$ (MHz)	1.4	3	5	10	15	20
N_{RB}	6	15	25	50	75	100

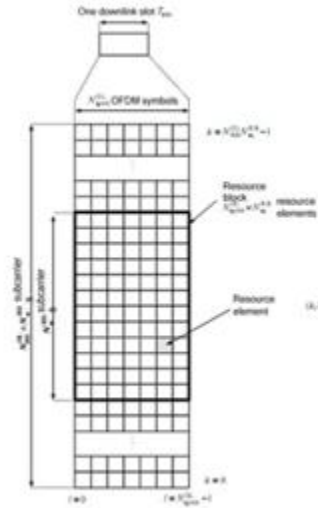

Fig. 8 Downlink resource grid

For the chosen configuration, each resource block corresponds to 12 subcarriers, which at 15 KHz subcarrier spacing amounts to 180 KHz of spectrum. Hence, at 20 MHz channel bandwidth, the 100 available resource blocks occupy 18 MHz of channel bandwidth. As shown in Fig.8, The transmitted signal in each slot time is described by a

resource grid of $N_{DL} N_{RB}$ subcarriers & N_{DL} OFDM symbols [2]

Where

- N^{DL} : Downlink bandwidth configuration
- N^{RB} : Resource block size in the frequency domain
- $N_{DLsymbol}$: Number of OFDM symbols in a downlink slot

The actual number of data symbols mapped to resource elements per subframe depends on the

- Resource elements occupied by Cell-Specific Reference (CSR) signals used for channel estimation.
- Control signaling region Physical Downlink Control Channel (PDCCH).
- Resource elements occupied by primary (PSS) and secondary (SSS) synchronization signals.
- Resource elements occupied by transmission of the broadcast channel (PBCH).

Since some of these signals are not transmitted every subframe, the size of the data payload varies over the subframes in a radio frame.

Cell-Specific Reference Signals

The Reference Signal (RS), known also as pilot is inserted in specific sub-carriers. An IFFT (Inverse Fourier Transform) is then applied to the sub-carrier in the transmission bandwidth

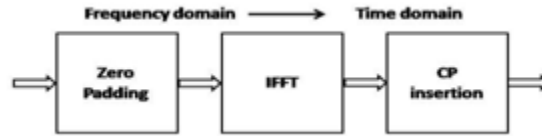

Fig. 9 The structure of OFDM modulation

OFDM

OFDM is a multicarrier modulation technique, which provides high bandwidth efficiency because the carriers are orthogonal to each other and multiple carriers share the data among themselves. The main advantage of this transmission technique is their robustness to channel fading [12].

Orthogonal Frequency Division Multiplexing (OFDM) is a basic technology of LTE, which is used in the downlink transmission scheme. OFDM can be seen as a kind of multi-carrier modulation, which divides a large system bandwidth into multiple narrowband sub-carriers. This makes each sub-carrier nearly flat fading. The use of cyclic-prefix mitigates intersymbol interference in a time- dispersive channel.

There are several basic parameters of OFDM in this simulator, such as the sub-carrier spacing Δf , the number of subcarriers (N_{sc}), the cyclic prefix length (N_{CP}) and the FFT size (N). As shown in Table. 2, a sub-carrier spacing of 15 kHz is used and the latter three parameters are decided by the system bandwidth (BW). There are also other related parameters in this table, like the sampling frequency f_s and the number of OFDM symbols in a slot (N_{Symb}). The cyclic prefix length is specified in terms of samples, while in the specification [5], it is in terms of unit time.

OFDM generation for each antenna port for is illustrated in Fig.9. The zero padding process is shown in Fig.10 (the first value after zero padding is an unused DC-sub-carrier and the blank part in the figure is padded with zeros). An IFFT transforms frequency-domain signals into time- domain signals, i.e. OFDM symbols. The Cyclic Prefix (CP) insertion copies the last N_{CP} samples of the OFDM symbol and appends them at the beginning of the symbol

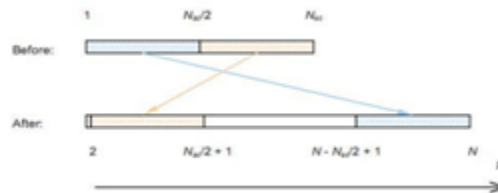

Fig. 10 Zero padding of OFDM modulation.

Table 2: Downlink OFDM parameters

BW (MHz)	1.4	3	5	10	15	20
Δf	15 KHz					
N_{sc}	72	180	300	600	900	1200
N	128	256	512	1024	1536	2048
f_s	1.92	3.84	7.68	15.36	23.04	30.72
N_{CP}	7/6 (normal/extended CP)					
N_{CP}	9	18	36	72	108	144
	32	64	128	256	384	512

MIMO Channel Model

The MIMO Fading Channel block implements the MIMO fading profiles as LTE standard [5].

The multipath propagation conditions consist of several parts:

- A delay profile in the form of a "tapped delay-line", characterized by a number of taps at fixed positions on a sampling grid. The profile can be further characterized by the r.m.s. delay spread and the maximum delay spanned by the taps.
- A combination of channel model parameters that include the Delay profile and the Doppler spectrum, which is characterized by a classical spectrum shape and a maximum Doppler frequency
- A set of correlation matrices defining the correlation between the UE and eNodeB antennas in case of multi-antenna systems.
- Additional multi-path models used for Channel Quality Indication (CQI) tests.

MIMO Receiver

MIMO receiver subsystem which includes:

- Channel estimation employs least-squares estimation using averaging over a subframe for noise reduction for the reference signals, and linear interpolation over the subcarriers for the data elements. This uses the CSR signals for the channel estimates [13].

Table 3: Simulation parameters

Parameter	Value
Channel Bandwidth	5 MHz
Duplex Mode	FDD
Channel Type	EPA 5Hz
FEC Coding	Turbo Coding 1/3
Modulation	QPSK, 16-QAM, 64-QAM
Subcarrier Spacing	15 KHz
Code Rate	0.75
Antenna Diversity	2X2 and 4X4 MIMO

- Codebook selection employs the Minimum Mean Squared Error (MMSE) criterion to calculate the codebook index per subframe [12].
- MIMO receiver employs a linear MMSE receiver to combat the interference from the multiple antenna transmissions.

III. SIMULATION RESULTS

The performance of LTE physical layer was tested and evaluated at different noise levels. Various BER vs SNR and data throughput vs SNR plots are presented for all essential modulation. Performance analysis results are provided using FDD operation and through MIMO fading channel. Our results are based on MATLAB simulations for which the relevant parameters are summarized in Table3.

For better understanding of the LTE performance, results are classified as two main categories: 5 MHz of system bandwidth utilizing 2x2 MIMO, and 5 MHz of system bandwidth utilizing 4x4 MIMO in downlink.

Fig. 11 to 14 Show the scatter plots for 64-QAM modulation at the receiver at different values of SNR for 2x2 MIMO and 4x4 MIMO. It can be observed from scatter plots that spread reduction is taking place with the increasing values of SNR.

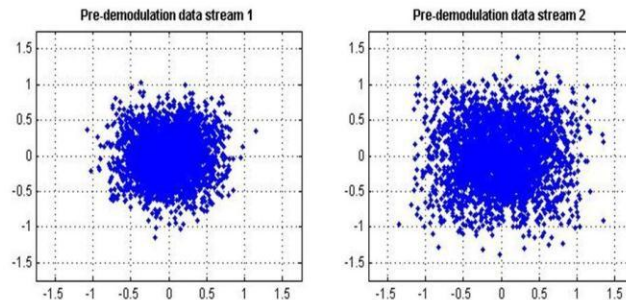

Fig. 11 Scatter Plot for 64-QAM 2x2 MIMO at SNR = 5dB.

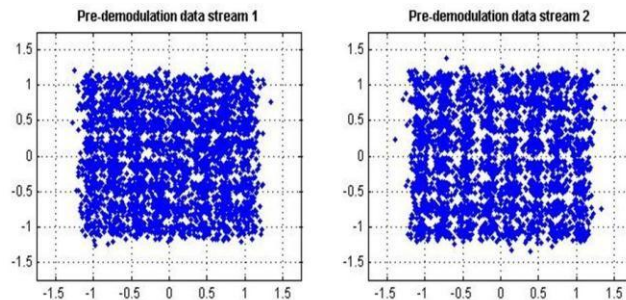

Fig. 12 Scatter Plot for 64-QAM 2x2 MIMO at SNR = 20dB.

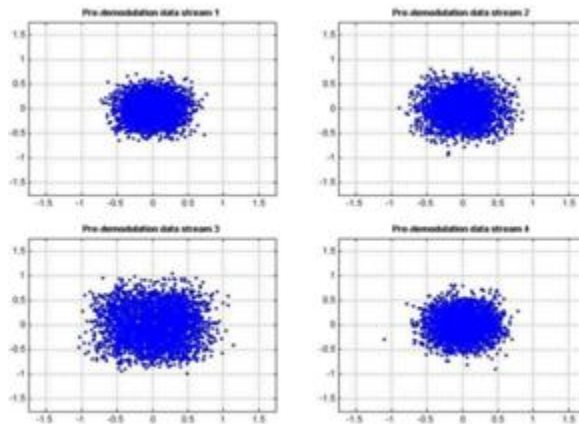

Fig. 13 Scatter Plot for 64-QAM 4x4 MIMO at SNR = 5dB.

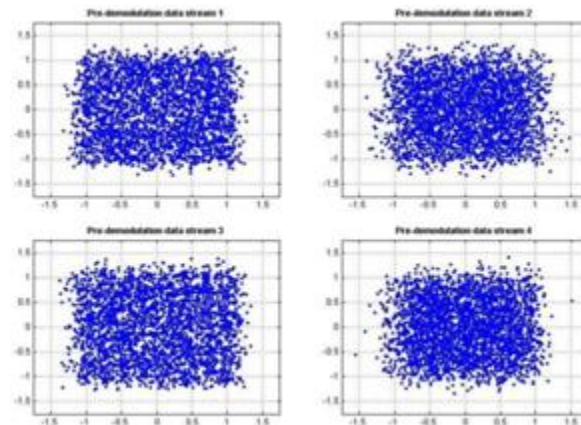

Fig. 14 Scatter Plot for 64-QAM 4x4 MIMO at SNR = 20dB

LTE CBER

Fig.15 and 16 illustrate the codeword bit error rate (CBER) values for two codeword for codebook index 1 as specification of 3GPP release 10 using QPSK, 16-QAM and 64-QAM. The two MIMO techniques (2X2 and 4X4) are applied. It can be noticed that the lower modulation scheme provides better performance with less SNR, furthermore, The selection of the AMC mode is made in such a way that guarantees a BER below a given target BER. As the modulation is 64-QAM. A relatively high SNR is observed for the good BER performance. In fact, The BER of 10^{-3} is achieved with 28 dB of SNR in 4x4 MIMO configuration however the same value of BER is achieved with only 24 dB in the 2x2 diversity scheme. So an SNR gain of 4 dB is clearly observed for 2x2 diversity scheme.

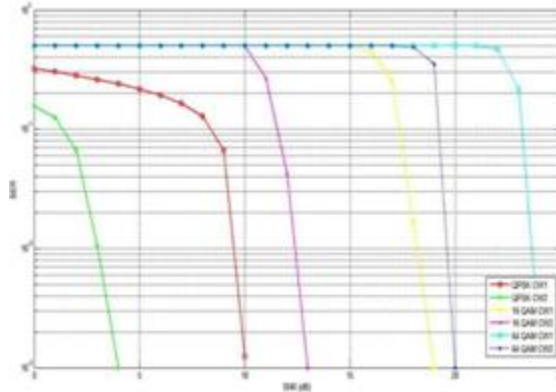

Fig. 15 CBER vs SNR for 2x2 MIMO.

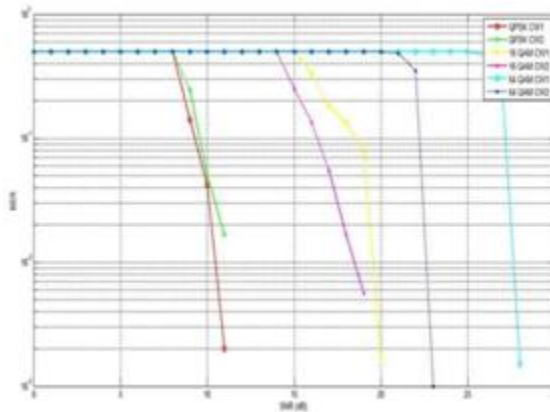

Fig. 16 CBER vs SNR for 4x4 MIMO

Data Throughput

The data throughput results of the two MIMO schemes are presented in the Fig.17 and 18 for FDD operation based on mentioned parameters in Table.3, the data throughput of 2x2 MIMO configuration is shown in Fig.17. It can be observed that as the SNR increases, the data throughput increases and it reaches its maximum at almost 24 dB SNR. As in CBER, the high-order modulation is behind the high SNR required to achieve the maximum capacity of 30 Mbps in the PDSCH channel.

The data throughput of 4x4 MIMO configurations is shown in Fig.18. It can achieve the maximum data throughput of 74 Mbps at SNR 28 dB. When the eNB uses the bandwidth of 5 MHz for transferring data to the user equipment in the PDSCH channel by using 64-QAM and code rate 0.75.

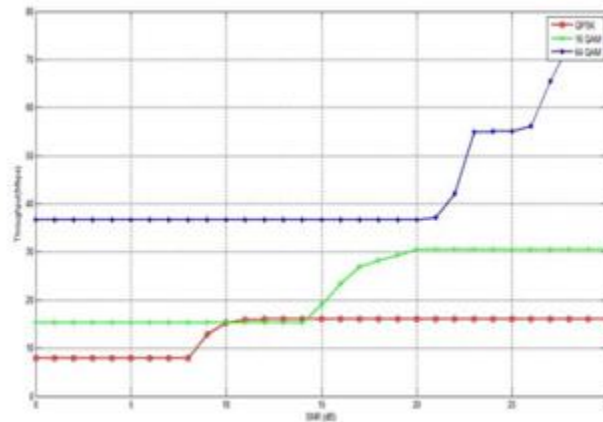

Fig. 17 2X2 MIMO Downlink Throughput in 5 MHz bandwidth.

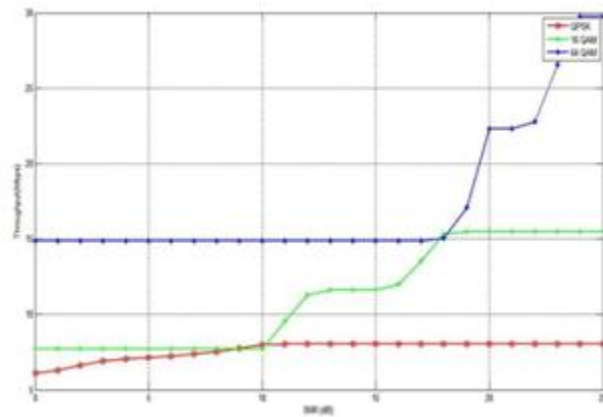

Fig. 18 4X4 MIMO Downlink Throughput in 5 MHz bandwidth.

IV. CONCLUSION

The paper has analyzed the performance of LTE-A (Release 10). The analysis has focused on the main feature involved in the downlink, like the user multiplexing, adaptive modulation and support for multiple antennas through MIMO fading channel. The present results in this paper show that, LTE-A can achieve 74 Mbps of downlink data throughput for PDSCH and 10^{-3} CBER when using 64-QAM, 0.75 code rate and 4x4 MIMO.

The future work is aimed to implement the LTE-A downlink physical layer using FPGA and focusing on the ongoing in the LTE specification process

REFERENCES

1. "Introducing LTE Advanced," Agilent Technologies, Application Note 5990-6706EN, November 2010.
2. 3GPP Technical Specification Group Radio Access Network; "Evolved Universal Terrestrial Radio Access (E-UTRA); Physical channels and Modulation (Release10)", 3GPP TS 36.211 v10.0.0 (2010-12).
3. 3GPP Technical Specification Group Radio Access Network; "Evolved Universal Terrestrial Radio Access (E-UTRA); Multiplexing and channel coding (Release10)", 3GPP TS 36.212 v10.0.0 (2010-12).
4. 3GPP Technical Specification Group Radio Access Network; "Evolved Universal Terrestrial Radio Access (E-UTRA); Physical layer procedures (Release10)", 3GPP TS 36.213 v10.0.0 (2010-12).

5. [5] 3GPP Technical Specification Group Radio Access Network; “Evolved Universal Terrestrial Radio Access (E- UTRA); User Equipment (UE) radio transmission and reception (Release10)”, 3GPP TS 36.101 v10.0.0 (2010- 10).
6. 3GPP Technical Specification Group Radio Access Network; “Evolved Universal Terrestrial Radio Access (E- UTRA); User Equipment (UE) radio access capabilities (Release10)”, 3GPP TS36.306 v10.0.0 (2010-12).
7. 3GPP Technical Specification Group Radio Access Network, “Evolved Universal Terrestrial Radio Access (E- UTRA); Base station radio transmission and reception (Release10)”, 3GPP TS36.104 v10.0.0 (2010-09).
8. M. Abdullah, “Peak Throughput of LTE Release10 for Up/Downlink Physical Layer,” *International Journal of Information and Network Security (IJINS)*, VOL.1, NO.2, pp.88–96, 2012.
9. E. Dahlman, S. Parkvall, J. Skold, and P. Beming, “3G Evolution: HSPA and LTE for mobile broadband”, Academic Press, 2010.
10. X. Guo and P. Song, “Simulink Based LTE System Simulator.”, Chalmers University, Göteborg, Sweden, 2010, Report No. EX097/2010.
11. J. C. Ikuno, “System Level Modeling and Optimization of the LTE Downlink,” March2013.
12. F. M. Gutierrez, “Implementation of Tx/Rx OFDM System on FPGA.”, Universitat Politècnica de Catalunya, April 2009.
13. J. B. Jethva, M. K. Porwal, and A. R. Trivedi, “Performance Analysis for Different Modulation Schemes in MIMO for LTE and WLAN.”, *International Journal of Emerging Technology and Advanced Engineering (IJETAE)*, Volume 3, Issue 5, May 2013, pp:580-583.